

# DEFINITION OF A KNOWLEDGE REPRESENTATION BASED ON FUNCTIONAL CAD MODELS

Jean-Bernard Bluntzer<sup>1</sup>, Samuel Gomes<sup>1</sup> and Jean-Claude Sagot<sup>1</sup>

(1) University of Technology of Belfort – Montbéliard

## ABSTRACT

How to merge the users' requirements into a complete design process has now become a reality. That is so in the automotive industry, from vehicle styling to specific facilities in connection with lifestyle evolution. Included in a globalizing lower cost approach, such requirements need to be processed quickly without impacting on the product robustness.

In this context, our paper lays out a specific design method based on Axiomatic Design methodology, and a functional analysis in order to reduce the time dedicated to routine engineering. Last but not least, our study provides an input for our Case-Based Reasoning (CBR) process. This method is directly integrated into our self-developed PLM system - Product Lifecycle Management- in order to work in a worldwide and collaborative design environment.

The first objective of our methodology is to define the CAD model geometry according to the modifications and the customer needs. Therefore, this CAD models will be connected with the cases from our CBR database. In order to manage such control, we can identify functional parameters and functional rules through the functional requirements and the input constraints. Moreover, we can extract the specific parameters and the specific rules from the older CAD models stored in the Product Data Management system or PDM from the previous and validated project. Our method explains how to obtain and link the different parameter types and rules through the definition of a theoretical Functional Knowledge which relates a 3D geometry entity to a customer need. This knowledge aims at giving an input to a knowledge management system. It also defines a specific architecture of the 3D CAD product based on the system components divided in functional entities, the latter being the inputs of our CBR database. This specific architecture is used in order to perform and lay the foundation of a Knowledge-Based Engineering methodology or KBE. Moreover, this specific CAD architecture enables us to develop our data mining methods included into our Case-Based Reasoning approach.

*Keywords: Case-Based Reasoning, Routine Engineering, PLM, CAD modeling, Knowledge-Based Engineering.*

## 1 INTRODUCTION

The market evolution of the past ten years has been oriented towards globalization in order to reduce the final product costs and decrease development time. In this context, it is also important to consider the growing need for improving product performance and for integrating user specifications throughout the complete design process. In fact, this new context has generated a new engineering kind of work [1] [2] which is now more collaborative and extended worldwide. Today, Internet provides us a way to answer this problematic. Web-based products which were formerly PDM or Product Data Management platforms and now PLM or Product Lifecycle Management platforms will help us to work synchronously and asynchronously worldwide [3]. To illustrate this, we can analyze the context of the automotive market. The major OEMs -Original Equipment Manufacturers- used to offer one product by segment. Today, in order to answer the market, they have different choices in the same segment and each new product is adapted precisely to the customer needs. For instance, we can quote electronic manufacturers who are able to launch several cell phones in the same year.

If we compare these two business segments which are totally different, we infer that the main difference between each product is exterior design. In this case, the main problematic in the development cycle is to plug the new A-surfaces on the internal components of the product.

In addition, in the automotive industry, Rezayat says that only 20% of the components used in a product are traditional "New Design", which can be called innovation. The other 80% are considered

as routine engineering which is split into two parts: the first 40% for the slight existing part modifications and the other 40% for the complete reuse of pre-existing or externally supplied parts [4]. Moreover, if we consider the product lifecycle from an OEM point of view [5], as described in figure 1, this routine engineering interacts in the “Product Concept” and the “Detailed Design” phases. Today, one of the tools used in these phases is the CAD system. In fact, the 3D CAD models are one of the most important inputs of the production phase.

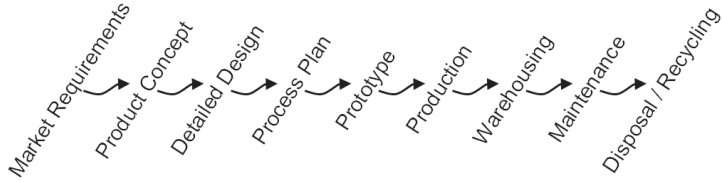

Figure 1. Stages in product life-cycle management from an OEM point of view

In this context, the main objective of this paper is to carry out a methodology in order to decrease time devoted to such a routine engineering, the aim being 50% of the time against 80% today. This tends to allocate more resources for innovation, namely 50% of the time against 20% today [6].

The following methodology lays out a general approach linking different points of view about the product using a systemic approach [7] and based on axiomatic design [8]. This methodology describes how to build a functional CAD model in interaction with a knowledge engineering approach, in order to create a new type of knowledge (K) called Functional Knowledge ( $K_f$ ). This functional Knowledge will be used in our Case-Based Reasoning (CBR) [9] approach data base, so as to be reused in new cases.

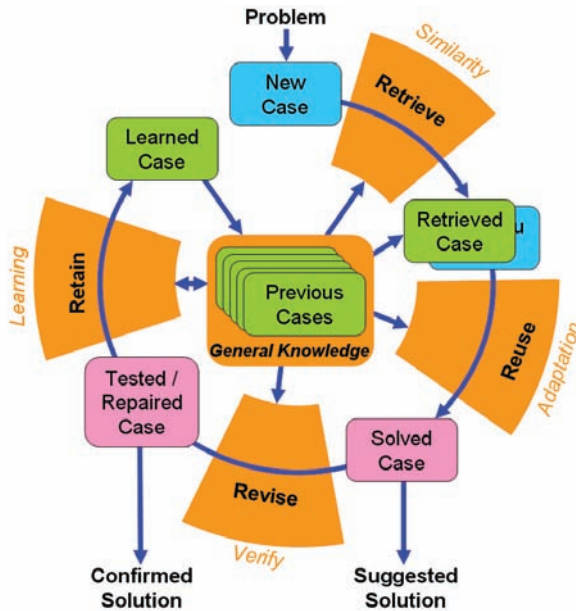

Figure 2. Case-Based Reasoning model [9]

## 2 PROPOSED METHODOLOGY AND TOOLS

In a global collaborative approach and Using a PLM system [10], the designer always follows the same generic design steps by using a vectorial definition: from customer requirements to technical parameters or manufacturing operations. These design steps are described in the following items:

1. Understanding of the customer needs. In this approach, it is necessary to list the different specifications as a "Requirements" vector:  $R = [r_1 ; \dots ; r_n]$ , with a n size,

2. Definition of the problem and functions in order to respond to these specifications. The list of the functional requirements are represented as a "Functions" vector:  $F_u = [fu_1 ; \dots ; fum]$ , with a  $m$  size,
3. Development of a solution for the product based on the evaluation of different solution principles. This solution includes several components or parts which are listed in a "Parts" vector:  $P = [p_1 ; \dots ; pk]$ , with a  $k$  size.
4. Analysis and optimization of the retained solution with an identification of the technical characters in each part, sub-assemblies or assemblies, which are represented in a "Technical or specific parameters" vector  $T = [t_1 ; \dots ; tu]$ , with a  $u$  size.
5. Optimization of the objective functions according to expert rules and design constraints: Rules vector:  $R_u = [F_1(X) ; \dots ; F_i(X)]$  with  $X = [x_1 ; \dots ; xn+u]$ , dimension vector  $n+u$ : concatenation of the  $R$  vector =  $[r_1 ; \dots ; rn]$  and the  $T$  vector =  $[t_1 ; \dots ; tu]$ ,
6. Validation of the customer specifications with a validation loop.

In this paper, we will reduce our analysis to the functional and structural aspects applied to a parametric and topological modeling approach.

### 2.1 Parametric Approach

Our methodology is divided into four step depicted on the figure 3.

The first step of our methodology is performed by the prescriber -the marketing manager for instance- and based on customer needs. This step allows the designer to list requirements in order to find the functions of the newly-developed product. This specification list is implemented into the database of our self-developed and web-based [11] ACSP PLM system [12], such as "Life Situation", "Function", "functional parameters", "specific parameters", etc.

In this first step, the technological context of the product design can be defined as routine or innovative engineering. Depending on this context, the product architect can build a new product structure based on a previous design case -routine design [13] - or on a new concept -Innovative design. This product architecture is then implemented into the ACSP PLM using the following fields in the database: "Product", "Product configuration", "Electronic Bill of Material (EBoM)", "Parts", etc.

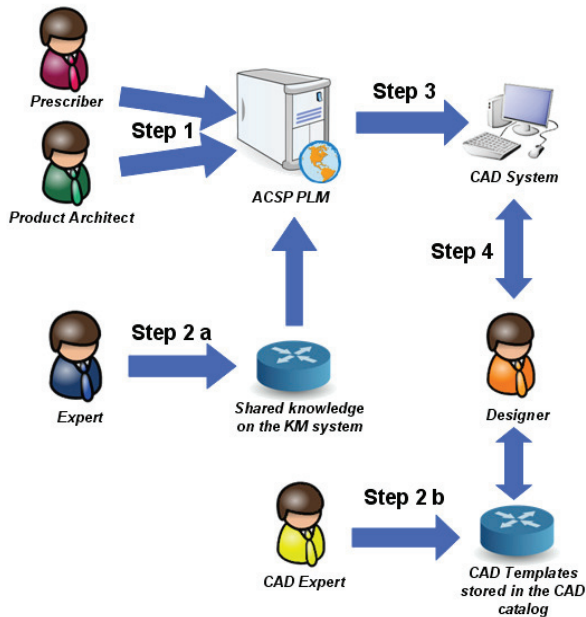

Figure 3. Methodology model

The second step is performed by experts (Step 2a), in parallel with the first one. It allows to integrate the expert rules based on previous projects capitalized into our Expert Knowledge System with the help of artificial agents in the ACSP PLM system.

These expert rules are then implemented into our PLM ACSP using the following fields: “Functional rules” and “Specific rules”. Meanwhile, the CAD expert (Step 2b) builds specific generic CAD Models also called CAD templates, using specific KBE or Knowledge Based Engineering [14] software in order to automate the routine design activities in a geometrical CAD modeler.

Based on the previous data implemented into the ACSP PLM system -product architecture, specific parameters, functional rules, etc-, our third step consists in generating CAD scripts automatically. These scripts allow creating automatically in the CAD modeler the parameterized product architecture including the product rules and conform to the functional specifications stored in the ACSP environment.

The fourth and final step is performed by the CAD designer. Using the CAD templates, the generated tree [15] of the CAD model including design rules and parameters, the designer is now able to build the CAD model faster. This CAD model will be in accordance with all the expert rules and driven by functional specifications.

## 2.2 CAD model architecture

In this paper, we will illustrate this approach with a commercial software issued by the Dassault System Company called CATIA v5. In order to identify knowledge in a CAD definition, each file must have the same global architecture. Our methodology suggests five levels in a CAD definition.

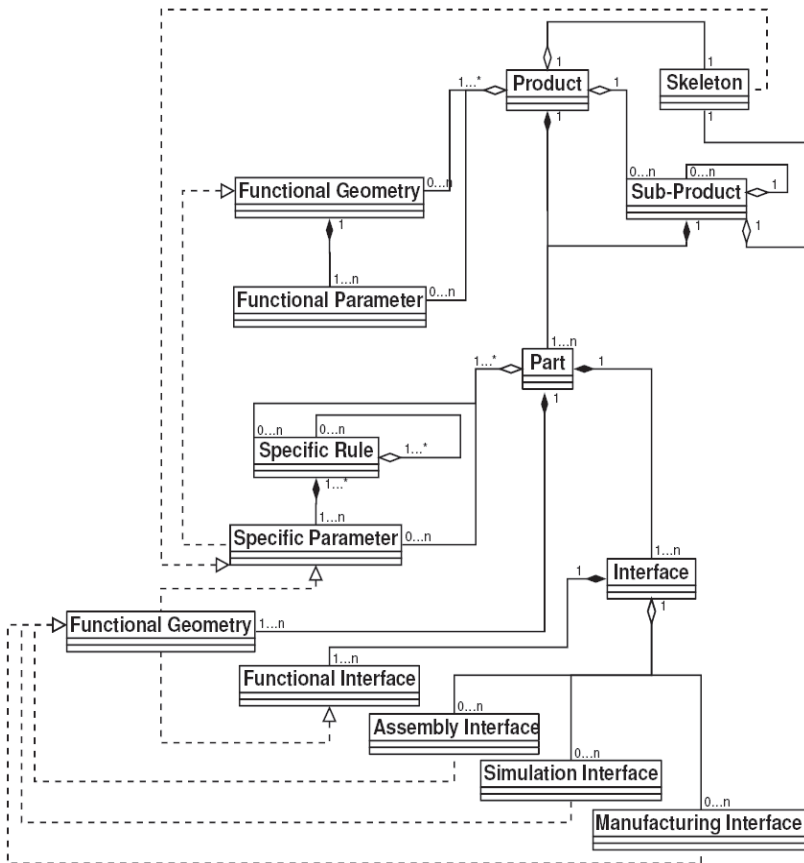

Figure 4. Generic architecture of a CAD model using UML representation

As illustrated in Figure 4, they can be defined as follows:

- Assembly (A): It is composed of sub-assemblies cinematically linked together.
- Sub-assembly (SA): It aggregates parts and each part is cinematically fixed to another one and has no degree of freedom. A sub-assembly does not include cinematic links between parts.
- Part (P): It is composed of functional organs and functional interfaces. Each component is cinematically fixed to another one.
- Functional Organ (FO): It is a geometrical component of the part. The geometry of the functional organ is driven by specific parameters. This geometry answers to functional specifications.
- Functional interface (FI): It is a wireframe component from the part. This component is the foundation of the functional organ and performs the interface between the different parts.

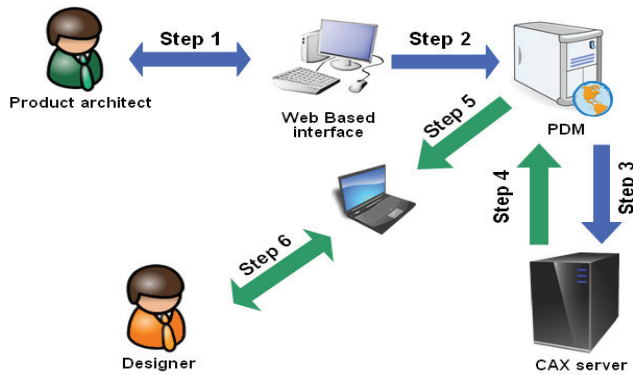

Figure 5.  $G_f$  extraction model

If each CAD model is built with this approach, we can extract from each model the same kind of information using a generic method. This method is described in the figure 5, and performed in 6 steps after the CAD model check-in into the ACSP PLM, and explodes it in several parts called functional Geometry ( $G_f$ ).

- Step 1: The product architect checks-in his new CAD model into the Web-Based interface.
- Step 2: The CAD model is uploaded into the data base of the PDM server.
- Step 3: The PDM server launches a CAD software on a CAX server in order to perform the exploding operation. In our case, we launch CATIA v5 and a Visual Basic script.
- Step 4: The CAX server returns the process output, in our case, several new parts.
- Step 5: The new parts are accessible on the web-based interface.
- Step 6: Any designer can view and use this new  $G_f$ .

Each generated  $G_f$  is now composed of a single Functional Organ (FO) based on its Functional Interface ( $F_i$ ). The following equation formalizes this method:

$$P = \sum_{1 \leq n \leq \infty} (FO_n + FI_n) \quad (1)$$

$$G_f = FO + FI \quad (2)$$

$$P = \sum_{1 \leq n \leq \infty} G_{f_n} \quad (3)$$

The first equation shows that the part is composed of functional organs and functional interfaces. The second equation explains the functional geometry and the third equation concatenate the first and the second equation in order to explain that a part is composed of several functional geometries.

### 3 DEFINITION OF THE KNOWLEDGE REPRESENTATION

To create a new type of Knowledge, it is important to understand the approach of knowledge engineering. It can be defined as follows: knowledge engineering provides material and human resources to produce, share, maintain, protect and refresh the knowledge of the external environment of the company (Economic Intelligence) and the internal environment of the company (Knowledge Management) [16].

It is also important to understand the difference between data, information and knowledge. To explain these three concepts, we can retain Tom Davenport and Larry Prusak's definitions given in 1998 [17]. A data is a set of discrete, objective facts about events that are usually stored in some form of information technology system. Information is data with meaning. Knowledge is a fluid mix of framed experience, values, contextual information, and expert insight that provides a framework for evaluating and incorporating new experiences and information. It originates and is applied in the mind of knowers.

#### 3.1 $I_f$ identification

In our methodology, we are in possession of two linked data:

- The Customer need, represented by the vector "R"
- A functional geometry, called  $G_f$ , composed by a functional organ and its functional interface

Using the previous definition of the information (called I) and in order to create a new type of I, the most appropriate algebra to formalize the link between these two data and obtain a I is the Union operator, and can be written as follows:

$$I_f = R \cup G_f \quad (4)$$

#### 3.2 Extrapolation of a $K_f$

Based on the Tom Davenport and Larry Prusak's definitions, knowledge is produced when information is available for review by a "knower". One of the possible ways to expose for an  $I_f$ , is the PDM. In our methodology, each  $I_f$  is implemented into our ACSP PLM system.

To formalize this sentence, the addition operator is used. With this link, we can connect the  $I_f$  and the "knower" (called H in the formula) in order to write the  $K_f$  equation.

$$K_f = I_f + H \quad (5)$$

#### 3.3 Usage of a $K_f$

The most important point is that we can now manage this new type of knowledge with the traditional methodology of knowledge management. In fact, this management can be describing as follows:

- Share: Through the PLM ACSP, we can use the  $K_f$  at each step of the product workflow.
- Maintain: The  $K_f$  is plugged with several indicators. For example: cost, quality, robustness, etc.
- Protect: the  $K_f$  is totally integrated into the PDM system and therefore has the same security than the other technical data.
- Refresh: The  $K_f$  is also viewable by an expert, and can be updated if the  $G_f$  or R are evolving

We will see how we can reuse a  $K_f$  in the next section which describes an experimental case.

### 4 EXPERIMENTATION APPLIED TO AN AUTOMOTIVE COMPONENT

Our methodology is illustrated by an experiment with a plastic component from an automobile front bumper. This item called sensor support relates the bumper skin to the proximity sensor, as described in figure 6, and is coupled with a design area.

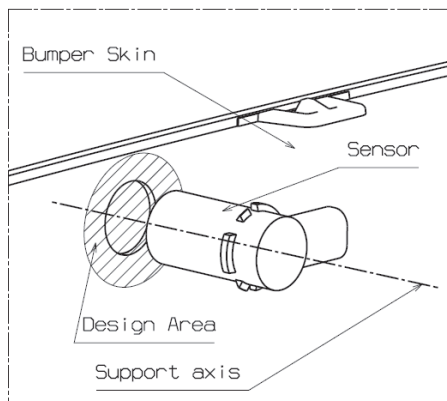

Figure 6. General overview of the item environment and the design area

This item is in contact with the bumper skin and the sensor of the same vehicle. In this experimental case, we simulate the collaboration OEM – Supplier, therefore, we need to supply the sensor support to the OEM. The functional requirements of the OEM include the minimum pull-off strength between the sensor support and the bumper skin, the fitting force of the sensor in its support, and the skin master draft of the bumper skin. Product lifecycles from the supplier and the OEM's viewpoints have the same architecture as shown in Figure 1. However, some differences are displayed in the first two steps. In fact, the “market requirements” have become “customer requirements” and the “product concept” have changed into “request for quotation”.

#### 4.1 Product architecture

In order to generate the parameterized and regulated product architecture, the following criteria need to be implemented into our ACSP PLM at first.

- The product architecture: it is based on the previous project and generic knowledge or design experiment validated by experts.
- The functional rules and parameters: based on the specifications, functional parameters impact on the product directly, independently from the chosen solution. In our case, the minimum pull-off strength between the sensor support and bumper skin ("F\_a"), the fitting force of the sensor in its support ("F\_m"), and the skin master draft of the bumper skin (“A-Surfaces”) are functional parameters. Therefore, they impact directly on the sensor support, independently from the retained solution.
- The specific parameters and rules are based on expert knowledge and previous cases. When this kind of parameters and rules are validated by experts, they will impact the product specifically and are independent from the retained solution. For example, the sensor support includes the specific parameters called “Thickness” which drives its theoretical constant thickness -expert rule in plastic design. The specific rule linked to this specific parameter is depending on the chosen solution.

Figure 7 illustrates a part of the first matrix of our methodology applied to the functional requirements of the sensor support. This matrix is defined in order to keep a traceability of the design choices. The requirements used in this matrix are defined as follows:

- R1: "F\_a"
- R2: "F\_m"
- R3: "A-Surfaces"

Two solutions can respond to these requirements. They are defined by the product architect.

- At first, the sensor support is assembled to the bumper skin with a removable link.
- Secondly, the sensor support is assembled to the bumper skin with an unremovable link.

In our case, we choose the second solution which enables us to extract the functional requirements of our sensor support:

- Fu1: To position the sensor on the bumper skin.
- Fu2: To fix the sensor on the bumper skin.

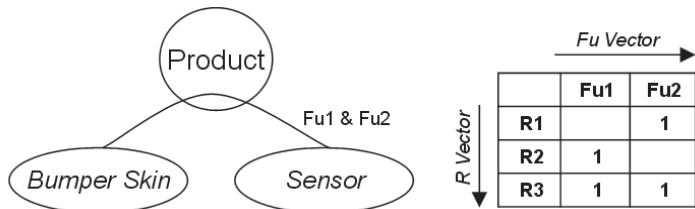

Figure 7. An example of the external functional analysis of our product and its corresponding matrix (R-Fu Matrix)

In the next stage, the product architect has to provide a technical solution corresponding to the first chosen architecture. He has to make a choice between three technical solutions regarding the unremovable link, as illustrated in figure 8: the clipping solution, the staple-fastening solution and the heading solution. We suggest the staple-fastening solution in our case.

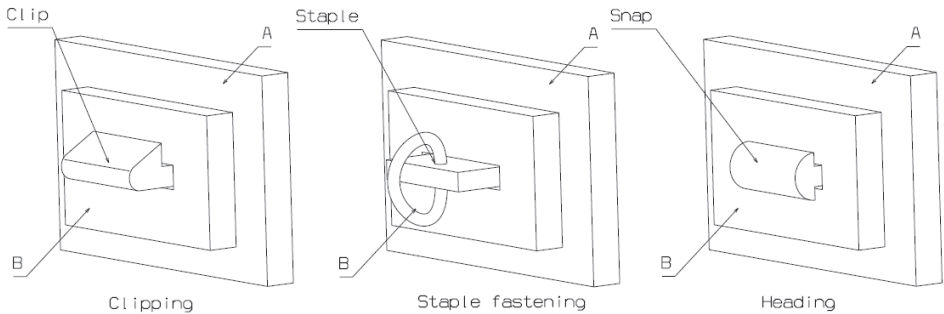

Figure 8: An example of the external functional analysis of our product and its corresponding matrix (R-Fu Matrix)

Figure 9 illustrates a part of the second matrix of our methodology, crossing functions with sub-assemblies and/or parts of the sensor support. This matrix is defined according to an internal functional analysis approach performed to optimize the product design and costs. The first goal of this internal functional analysis methodology is to reduce the product design to the only parts, in the case of an assembly, or functional geometries, in the case of only a part, involved in the functional flux. The sensor support is only one item. It is then split into two functional geometries, the “Skin interface” and the “Sensor interface” (Gf1). The former is the geometry in contact with the bumper skin, and the latter the geometry in contact with the sensor.

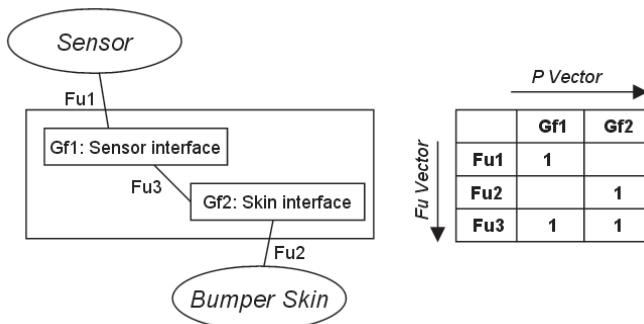

Figure 9. An example of internal functional analysis of our product and its corresponding matrix (Fu-P Matrix)



The second goal is to define the Functional requirements which depend on the internal architecture choice. In our case, we need to interface the bumper skin with the skin interface of our part. This function is called Fu2.

It is necessary to define all the specific parameters driving each part of the product contributing to build the specific parameter vector -vector T. As shown in Figure 10, a P-T matrix can be filled in order to get the links between functional geometries and technical parameters. In our example, we use three specific parameters.

- T1: Sensor diameter.
- T2: Number of wings.
- T3: A-Surfaces.

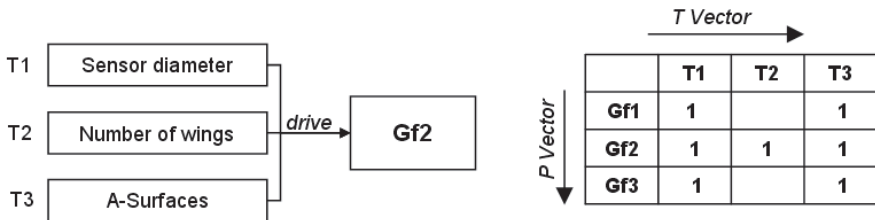

Figure 10. An example of internal functional analysis of our product and its corresponding matrix (P-T Matrix)

The next step consists in identifying the specific parameters of the product linked with each part in order to build a new vector X- resulting from the concatenation of the requirement R vector and the specific parameter T vector.

Table 1. Extract of the vector representation of the functional and specific parameters linked to the specific and functional rules in the case of staple fastening architecture type.

X	R	F <sub>a</sub> : minimum pull-off strength
		F <sub>m</sub> : fitting force
		...
	T	D : Sensor diameter
N : Number of wings		
...		

The previous table (Table 1) proposes a vector representation of different functional and specific parameters linked to the functional and specific rules of the integral body. This table is in accordance with the previously described functional, structural and geometrical knowledge-based design approach using our self-developed PLM system. At this step, it is possible to generate some Visual Basic scripts for CATIA v5 CAD modeler directly through our ACSP PLM system. These scripts launched in the CAD environment create a product architecture (product tree) automatically, including the various parts and sub-assemblies, and index, the functional and specific parameters and rules directly in the product tree, in association with the X vector previously described.

The last step consists in building geometry on the previously described product architecture -sub-assembly, parts, functional and specific parameters, rules, etc.- in order connect the requirements to the CAD model.

The main advantage of our proposed methodology is to link the customer specifications to the Digital Mock-Up directly while considering all the expert design rules. Thanks to this methodology, when a modification is done on the specification during the design process -modification of the functional parameters-, the structure of the retained solution will not be impacted and the reaction time of the modification will decrease with the direct impact on the Digital Mock-Up.

In Figure 11 example, we can drive the functional parameter “Minimum pull-off strength” (F-a) in order to obtain a reconfiguration of the impacted mechanical parts. In this case, the specific parameter

“Number of wings” of the sensor support is impacted if we change the functional parameter “Minimum pull-off strength t”.

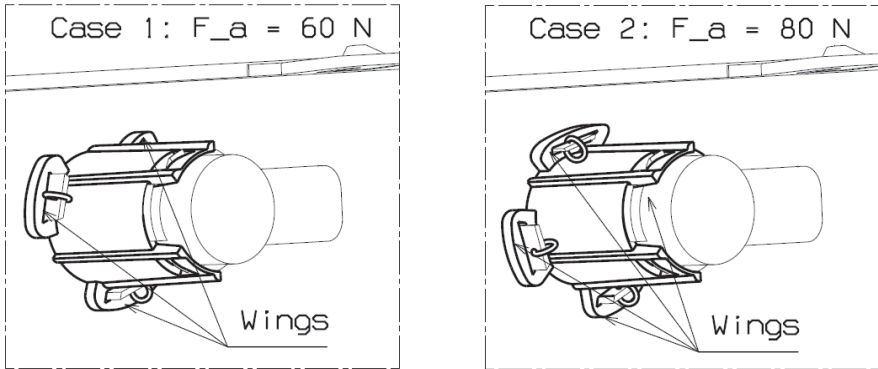

Figure 11. Modification examples of the “Total Weight” functional parameter.

With this system, we are now able to obtain a real range of products. The other advantages of our method are based on the use of our ACSP PLM:

- the collaborative and the multi-office aspects manage the check-in of the functional specifications and the product architecture. It is now possible to distribute a part of the Digital Mock-Up to each designer located in different offices worldwide.
- the propagation of the specific and functional parameters on the whole product using the internal functional analysis [18] [19] in order to identify each part which is impacted by the functional parameters and respectively, by the customer requirements.

Using the customer requirements and the expert rules implemented by the experts into the PLM ACSP, the product architecture can drive the parameterized product structure directly. Owing to the automatic generation of scripts to build the Digital Mock-Up, our proposed methodology allows collaborative and productive engineering, in accordance with the customer needs and in conformity with the company expert knowledge.

#### 4.2 K<sub>f</sub>: extraction, formalization and reuse

After the design of the part, the designer checks in his model into the PLM ACSP. This step integrates our CBR approach and tends to store a knowledge type identified into the CAD model in order to be reused in another case. At this stage, his model is exploded in several different K<sub>f</sub> stored into the knowledge database located in the PLM ACSP. Figure 12 shows you two different K<sub>f</sub>.

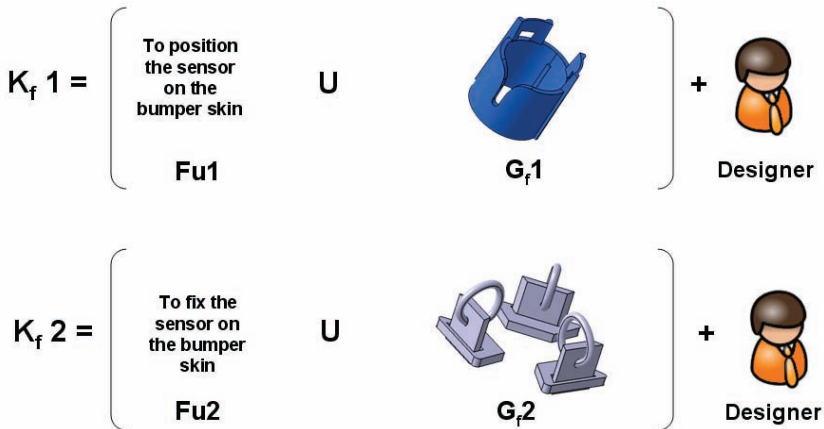

Figure 12. Examples of two generated K<sub>f</sub>.

If one of the designers needs to find a solution with the same input requirements in the next development program, the PLM ACSP will show him each  $K_f$  after the outcome of the new architecture. With these  $K_f$ , he can see the previous development, analyse it with the different indicators such as cost, robustness, etc., and reuse it.

## 5 CONCLUSION

This paper details the basis of our knowledge-based engineering and functional approach in order to reduce costs, lead time and also to improve product quality and value. We have also input our first case-based reasoning approach, with a required knowledge type definition to be stored and reused in next cases.

This methodology is based on a specific CAD architecture in order to link the customer needs defined by the axiomatic design directly to the Digital Mock-Up. To perform this link, our matrix-based approach allows to define the impacted parameters when a functional requirement is modified. Successively, the first matrix defines the external analysis (R-Fu matrix), the second one introduces the internal analysis (Fu-P matrix), the third one shows the specific parameters (R-Fu matrix) and the last one declares the parameters propagation (R-P matrix) into our specific CAD architecture. This architecture composed of the product, sub-assemblies and parts is now able to introduce the parameters in order to answer the technical sub-function and, allows to impact on the geometrical entities with the propagation (wireframe, shapes and solids).

To use this approach, each actor of the project uses our ACSP PLM in order to implement each requirement into our technical database. After the last human activity, our system generates the new CAD architecture automatically, including the propagation of the parameters and the expert rules. The output of this generation is a Visual Basic script readable by the chosen CAD system. The output of this generation is a Visual Basic script readable by the chosen CAD system. The CAD designer is now able to generate the new CAD model according the requirements and is reactive when a functional modification is engaged. In order to validate this approach, our experimental case describes a sensor support from the front bumper of an automobile. This case bears out the interesting aspects of our methodology and allows us to use it in a new industrial project in order to validate it in a realistic and complex environment.

The next step of our research will be more focused on the extraction of the tacit knowledge [20] stored into each CAD model, and laid on the identification and reuse of the previous cases in our CBR approach. The new  $K_f$  enables to extract it from the new CAD models, which are built with the good methodology. Today, thousands of kilobits of CAD models in each industrial company are stored whereas they are not built with this methodology. And this kind of data includes a lot of tacit knowledge. In order to exploit these data, our next research will be focused on a methodology which will extract the  $K_f$  of this CAD models using a data mining approach [21]. One of the possibilities is to use the geometrical identification approach.

## REFERENCES

- [1] D. Brissaud and O. Garro, "An Approach to Concurrent Engineering using Distributed Design Methodology." *Concurrent Engineering: Research and Applications*, 4(3): 303-311, 1996
- [2] Eynard B., Gomes S. "Collaborative and remote design of mechatronic products". In *Perspective from Europe and Asia on Engineering, Design and Manufacture*, Kluwer Academics Publishers, p261-270, 2004.
- [3] T. Kvan, "Collaborative Design: what is it?", *Automation in construction*, 9(4): 409-415, 2000
- [4] Rezayat, M. (2000). "Knowledge-based Product Development Using XML and KCs", *Computer-Aided Design*, 32(5): 299-309.
- [5] G. Thimm, S.G. Lee, Y.-S. Ma "Towards unified modelling of product life-cycles", *Computer in Industry* 57, 331-341, 2006.
- [6] Prasad, B, "Concurrent Engineering Fundamentals", PTR Prentice Hall, Upper Saddle River, New Jersey, 1996. VOL I: "Integrated Product and Process Organization", (ISBN 0-13-147463-4) and VOL II: "Integrated Product Development", (ISBN 0-13-396946-0).
- [7] G. Pahl and W. Beitz "Engineering Design: A Systematic Approach" Translated by K. Wallace, L. Blessing, and F. Bauert. Edited by K. Wallace, 2nd Edition. Springer-Verlag, New-York, 1995
- [8] Suh N.P., "Applications of Axiomatic Design" *Integration of process Knowledge into Design Support*, ISBN 0-7923-5655-1, Kluwer Academic Publishers, 1999.

- [9] Watson I. "Case-based reasoning is a methodology, not a technology". Knowledge-Based Systems, vol. 12, p. 303-308, 1999.
- [10] J. W. Shen, "Knowledge Sharing in Collaborative Design Environment", Computers in Industry, 52(1):1-3, 2003
- [11] D.T. Liu, and X.W. Xu, "A Review of Web-based Product Data Management Systems", Computers in Industry, 44(3): 251-262, 2001
- [12] S. Gomes, and J.C Sagot, "A concurrent engineering experience based on a cooperative and object oriented design methodology", Integrated Design and Manufacturing in Mechanical Engineering, Kluwer Academic Publishers, Dordrecht, 2002
- [13] C.M. Vong, T.P. Leung, P.K. Wong "Case-based reasoning and adaptation in hydraulic production machine design." Engineering Applications of Artificial Intelligence, vol. 15, p. 567-585, 2002.
- [14] D. E. Whitney, Q. Dong, J. Judson, C. Mascoli, "Introducing Knowledge-Based Engineering into an Interconnected Product development process." Proceedings of the 1999 ASME Design Engineering Technical Conference, September, Las Vegas, Nevada. DET99-DTM8741, 1999
- [15] S. Gomes, J.B. Bluntzer, J.C. Sagot. "Functional design through a PLM system for fastening routine definition of CAD models ". PLEDM 2006, Playa Del Carmen, Mexico, 26th november – 1st December, 9p, 2006.
- [16] F. Blondel, S. Edouard, M. N. El Mabrouk(2006) "Quelle articulation entre intelligence économique et knowledge management au sein de l'entreprise ? ", AIMS 2006
- [17] T. Davenport, L. Prusak, "Working Knowledge: How organizations manage what they know", Harvard Business School Press, 1998.
- [18] Norme Française X50-152, "Analyse de la Valeur, Caractéristiques fondamentales", 1990.
- [19] Norme Française X50-151, "Guide pour l'élaboration d'un Cahier des Charges Fonctionnel", 1991.
- [20] Kogut B. and Zander U., "Knowledge of the Firm, Combinative Capabilities and the Replication of Technology", Organization Science, p.383-397, 1992.
- [21] Chen, M. S., Han, J., & Yu, P. S. "Data mining: An overview from a database perspective." IEEE Transactions on Knowledge and Data Engineering, 8, 866–883, 1996.

Contact: Jean-Bernard Bluntzer  
 University of Technology of Belfort - Montbéliard  
 Department of Ergonomics, Industrial Design and Mechanical Engineering  
 Laboratory SeT – ERCOS Team  
 90010 Belfort Cedex  
 FRANCE  
 Tel: Int +33 384 583 013  
 Fax: Int: +33 384 583 141  
 E-mail: [jean-bernard.bluntzer@utbm.fr](mailto:jean-bernard.bluntzer@utbm.fr)  
 URL: <http://www.utbm.fr>

After technical studies concluded by a Master's degree in Mechanical Engineering and Design from the Belfort-Montbéliard University of Technology in 2006, Jean Bernard Bluntzer began scientific studies with a PhD work in partnership with an automotive supplier working on the bumper area. The main topic of the research, integrating collaborative design and knowledge management, is how to decrease the routine engineering time in the CAD area, and particularly on models based on complex shapes.